

Powder Coated Color Selection Guide

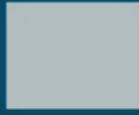

White
2129



Gray
2125



Charcoal
2123



Black
2127



Khaki
2115

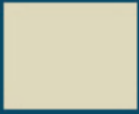

Almond
2103



Dark Khaki
2109



Red
2145



Burgundy
2148



Terra Cotta
2107



Azure
2101



Royal Blue
2135

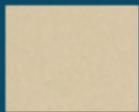

Sandy Beach
2150

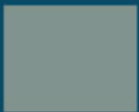

Sage
2141

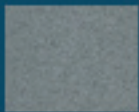

Pepper Dust
3590

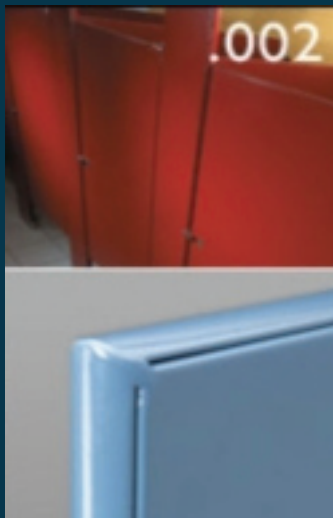

PART-1 GENERAL

1.01 DESCRIPTION

- A. Steel compartment work includes the following:
 - 1. Floor anchored/overhead braced partitions.
- B. Furnish all labor and materials necessary for the completion of work in this section as shown on the contract drawings and specified herein.
- C. Work in this section shall include but is not limited to:
 - 1. Toilet compartments
 - 2. Hardware for toilet compartments
 - 3. Shop drawings and working drawings
 - 4. Manufacturer's guarantee
- D. Related work specified elsewhere shall include accessories and anchorage/blocking for attachment of compartments.

1.02 PRODUCTS

- A. Submittal of shop drawings and details, for architects approval.
- B. Colors shall be selected from the manufacturer's standard range of colors.
- C. Color and hardware samples shall be submitted for approval to the architect upon request.

PART-2 PRODUCTS

2.01 MANUFACTURER

- A. Toilet compartments to be supplied by Global Partitions, Eastanollee, GA 30538.

2.02 MATERIALS

- A. Doors and panels shall be 1" thick, constructed of two sheets of 22-gauge, galvanized, stretcher-leveled quality steel formed and bonded under pressure with a non-toxic adhesive to a resin-impregnated, sound-deadening honeycomb core.
- B. Pilasters shall be 1-1/4", constructed of two sheets of 22-gauge, galvanized steel, formed and bonded under pressure with a non-toxic adhesive to a full resin-impregnated, sound-deadening full-face honeycomb core.

2.03 CONSTRUCTION

- A. Doors and panels shall be 1" thick. The perimeter shall be sealed with a 22-gauge steel interlocking molding. Molding corners shall be welded to each other and to face sheets and ground smooth to form a rigid frame around the component.
- B. Pilasters shall be 1-1/4" thick. The perimeter shall be sealed with a 22-gauge steel interlocking molding. An inverted stirrup with a jack bolt for leveling during installation and permanent height adjustment shall be welded within the base of each pilaster. "L" brackets shall be coupled to the stirrup bracket and floor for full range adjustment. A shoe shall conceal each mounting, having an internal cross section conforming to the pilaster, and being formed of type 304 stainless steel #4 finish.
- C. Headrail shall be provided to bridge all compartments and brace the end freestanding pilasters to the wall; the headrail shall be anodized aluminum satin finish, contoured to provide anti-grip feature.
- D. All units shall be cleaned prior to application of a baked GLO-GARD hybrid powder coating of at least 1.3 mil thickness.

2.04 HARDWARE (NOTE: Refer to the ORDER INFORMATION CONTRACT for specific hardware to be supplied on your order.)

- A. All exposed door hardware shall be of chromium-plated diecast Zamac and shall be as noted:
 - 1. Upper door hinge is recessed and interlocked in door and includes a nylon pin within the plane of the door. Lower door hinge is recessed in door and includes mating box and pintle nylon cams, which provide the bearing surface. The cams are adjusted to allow the door to rest at any position within a 270-degree range.
 - 2. Door hardware shall include a coat hook, bumper, stop, keeper and a concealed latch with emergency access.
- B. Wall brackets shall be secured to walls with anchoring and/or expansion shields.
- C. Pilaster shoes shall be of type 304 steel #4 finish.
- D. Fasteners shall be of chrome-plated steel; door hinges will be mounted with tamper resistant barrel nuts and machine screws; hooks and handles will be mounted with tamper resistant, full-thread screws.

PART-3 EXECUTION

3.01 PREPARATION

- A. Examine areas to receive toilet compartments for correct height and spacing of anchorage/blocking and plumbing fixtures that may affect installation of compartments. Report any discrepancies to the architect.
- B. Take complete and accurate measurements of toilet compartment locations.
- C. Start of work constitutes acceptance of job.

3.02 INSTALLATION

- A. Install compartments in a rigid, straight, plumb and level manner as shown on the shop drawings and manufacturer's installation instructions.
- B. All doors and panels to be mounted at 12" above the finished floor unless otherwise specified.
- C. Clearance at vertical edges of door shall be uniform top to bottom.
- D. No evidence of cutting, drilling and/or patching shall be visible on the finished work.
- E. Finished surfaces shall be cleaned after installation and be left free of all imperfections.

3.03 WARRANTY

- A. Global Partitions guarantees its powder coated steel units, properly maintained, against corrosion or discoloration for 3 years from the date of receipt by the customer. If materials are found defective during that period for the reasons listed above, the material will be replaced free of charge. No credits or allowances will be issued for any labor or expenses relating to the replacement of components covered under the warranty plan. All such expenses are to be borne by the buyer.

2.01

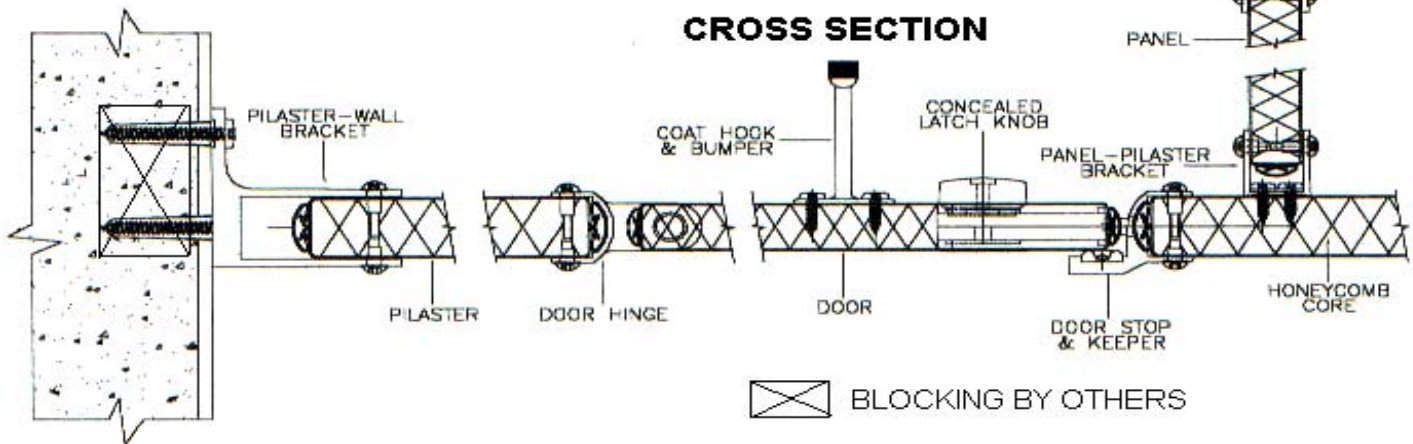
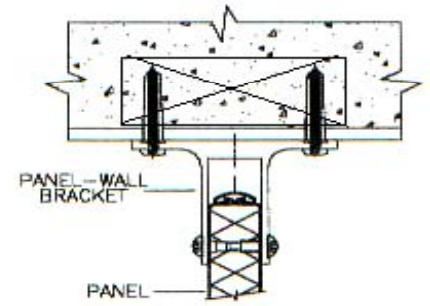
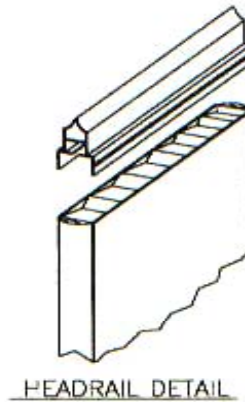
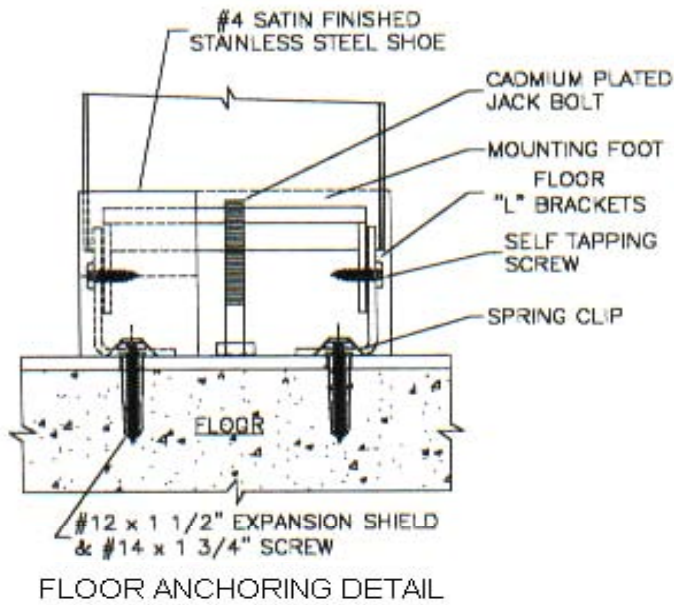
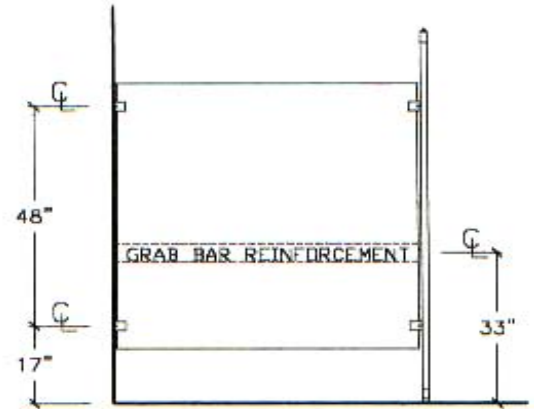
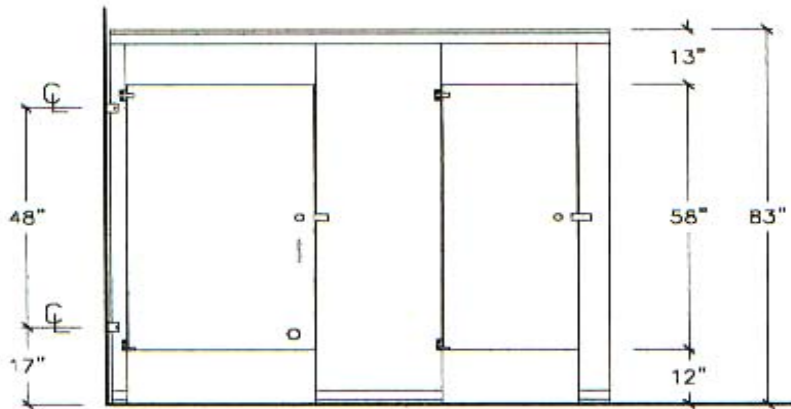

PART-1 GENERAL

1.01 DESCRIPTION

- A. Steel compartment work includes the following:
 - 1. Floor anchored partitions.
- B. Furnish all labor and materials necessary for the completion of work in this section as shown on the contract drawings and specified herein.
- C. Work in this section shall include but is not limited to:
 - 1. Toilet compartments
 - 2. Hardware for toilet compartments
 - 3. Shop drawings and working drawings
 - 4. Manufacturer's guarantee
- D. Related work specified elsewhere shall include accessories and anchorage/blocking for attachment of compartments.

1.02 PRODUCTS

- A. Submittal of shop drawings and details, for architects approval.
- B. Colors shall be selected from the manufacturer's standard range of colors.
- C. Color and hardware samples shall be submitted for approval to the architect upon request.

PART-2 PRODUCTS

2.01 MANUFACTURER

- A. Toilet compartments to be supplied by Global Partitions, Eastanollee, GA 30538.

2.02 MATERIALS

- A. Doors and panels shall be 1" thick, constructed of two sheets of 22-gauge galvanized, stretcher-leveled quality steel formed and bonded under pressure with a non-toxic adhesive to a resin-impregnated, sound-deadening honeycomb core.
- B. Pilasters shall be 1-1/4" thick, constructed of two sheets of 18-gauge galvanized steel, formed and bonded under pressure with a non-toxic adhesive to a full resin-impregnated, sound-deadening full-face honeycomb core.

2.03 CONSTRUCTION

- A. Doors and panels shall be 1" thick. The perimeter shall be sealed with a 22-gauge steel interlocking molding. Molding corners shall be welded to each other and to face sheets, and ground smooth to form a rigid frame around the component.
- B. Pilasters shall be 1-1/4", constructed of two sheets of 18-gauge galvanized steel, formed and bonded under pressure with a non-toxic adhesive to a resin-impregnated, sound-deadening full-face honeycomb core. Vertical edges shall be sealed with 20-gauge steel interlocking molding. The top of each pilaster shall be sealed with 20-gauge steel interlocking molding. An 11-gauge slotted stirrup bracket shall be integrally welded in to base of each pilaster. Two 3/8" diameter cadmium-plated studs anchor the mounting bracket to a concrete floor. A shoe shall conceal each floor mounting, having an internal cross section conforming to the pilaster, and being formed of type 304 stainless steel #4 finish.
- C. All units shall be cleaned prior to application of baked GLO-GARD hybrid powder coating of at least 1.3 mil thickness.

2.04 HARDWARE (NOTE: Refer to the ORDER INFORMATION CONTRACT for specific hardware to be supplied on your order.)

- A. All exposed door hardware shall be of chromium-plated diecast Zamac and shall be as noted:
 - 1. Upper door hinge is recessed and interlocked in door and includes a nylon pin within the plane of the door. Lower door hinge is recessed in door and includes mating box and pintle nylon cams, which provide the bearing surface. The cams are adjusted to allow the door to rest at any position within a 270-degree range.
 - 2. Door hardware shall include coat hook, bumper, stop, keeper and a concealed latch with emergency access.
- B. Wall brackets shall be secured to walls with anchoring and/or expansion shields.
- C. Pilaster shoes shall be of type 304 stainless steel #4 finish.
- D. Fasteners shall be of chrome-plated steel; door hinges will be mounted with tamper resistant barrel nuts and machine screws; hooks and handles will be mounted with tamper resistant full-thread screws.

PART-3 EXECUTION

3.01 PREPARATION

- A. Examine areas to receive toilet compartments for correct height and spacing of anchorage/blocking and plumbing fixtures that may affect installation of compartments. Report any discrepancies to the architect.
- B. Take complete and accurate measurements of toilet compartment locations.
- C. Start of work constitutes acceptance of job.

3.02 INSTALLATION

- A. Install compartments in a rigid, straight, plumb and level manner as shown on the shop drawings and manufacturer's installation instructions.
- B. All doors and panels to be mounted at 12" above the finished floor unless otherwise specified.
- C. Clearance at vertical edges of door shall be uniform top to bottom.
- D. No evidence of cutting, drilling and/or patching shall be visible on the finished work.
- E. Finished surfaces shall be cleaned after installation and be left free of all imperfections.

3.03 WARRANTY

- A. Global Partitions guarantees its powder coated steel units, properly maintained, against corrosion or discoloration for 3 years from the date of receipt by the customer. If materials are found defective during that period for the reasons listed above, the material will be replaced free of charge. No credits or allowances will be issued for any labor or expenses relating to the replacement of components covered under the warranty plan. All such expenses are to be borne by the buyer.

2.03

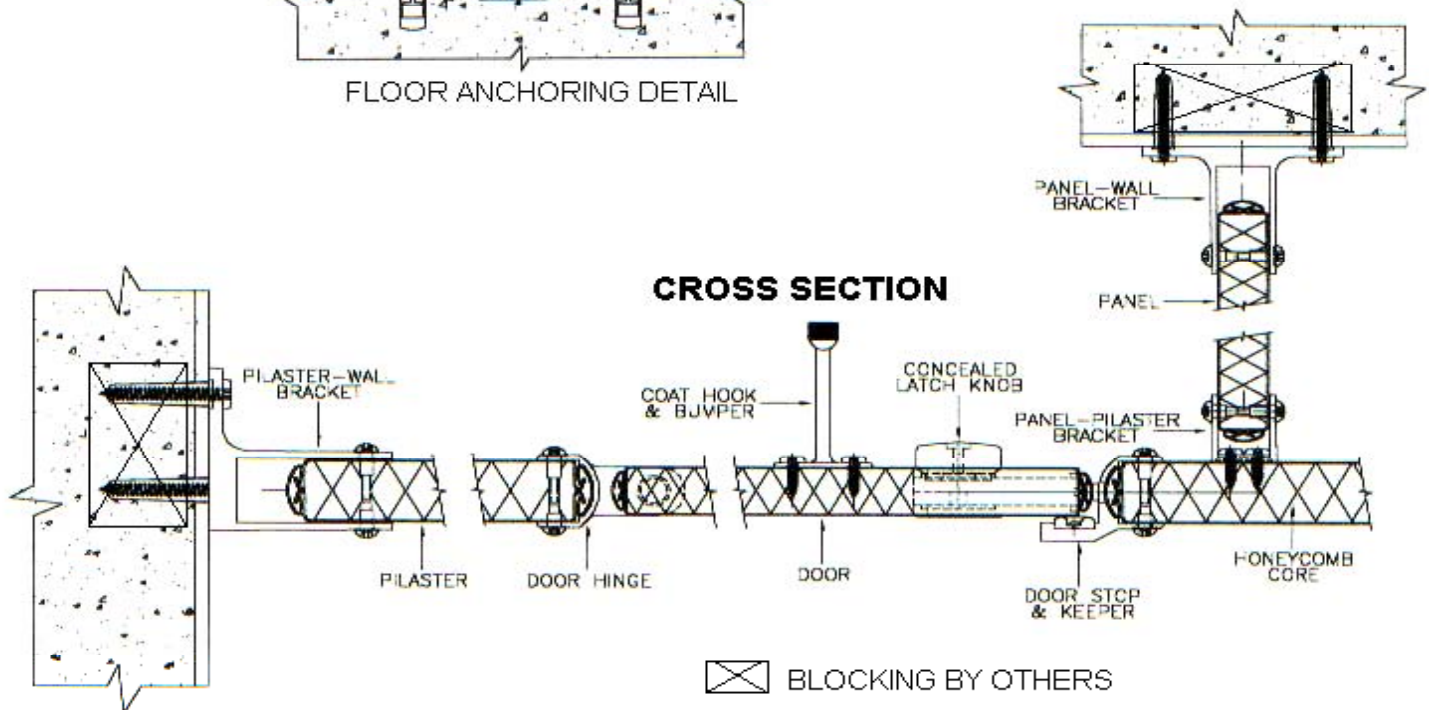
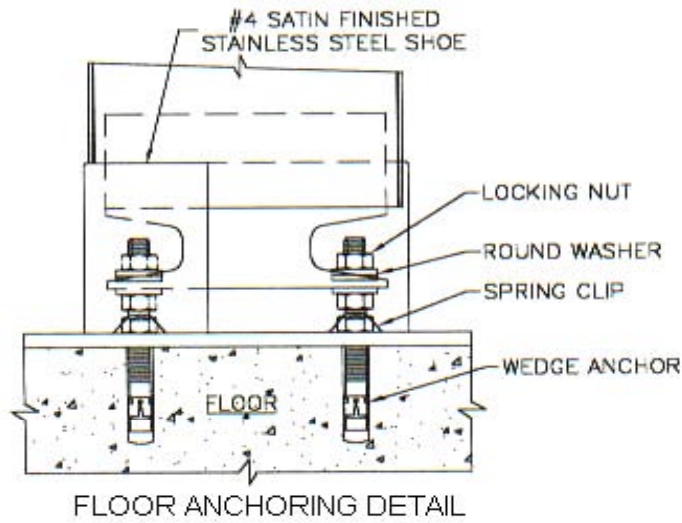
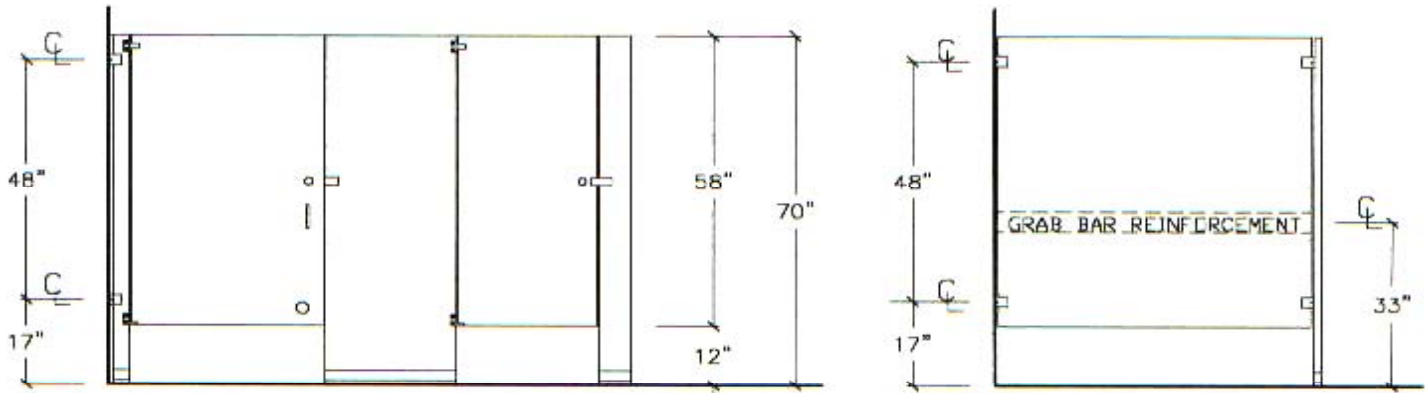

PART-1 GENERAL

**MAXIMUM CEILING HEIGHT 9'0"
MINIMUM CEILING HEIGHT 7'6"**

1.01 DESCRIPTION

- A. Steel compartment work includes the following:
 - 1. Ceiling hung partitions.
- B. Furnish all labor and materials necessary for the completion of work in this section as shown on the contract drawings and specified herein.
- C. Work in this section shall include but is not limited to:
 - 1. Toilet compartments
 - 2. Hardware for toilet compartments
 - 3. Shop drawings and working drawings
 - 4. Manufacturer's guarantee
- D. Related work specified elsewhere shall include accessories and anchorage/blocking for attachment of compartments.

1.02 PRODUCTS

- A. Submittal of shop drawings and details, for architects approval.
- B. Colors shall be selected from the manufacturer's standard range of colors.
- C. Color and hardware samples shall be submitted for approval to the architect upon request.

PART-2 PRODUCTS

2.01 MANUFACTURER

- A. Toilet compartments to be supplied by Global Partitions, Eastanollee, GA 30538.

2.02 MATERIALS

- A. Doors and panels shall be 1" thick, constructed of two sheets of 22-gauge galvanized stretcher-leveled quality steel formed and bonded under pressure with a non-toxic adhesive to a resin-impregnated, sound-deadening honeycomb core.
- B. Pilasters shall be 1-1/4", constructed of two sheets of 18-gauge galvanized steel, formed and bonded under pressure with a non-toxic adhesive to a full resin-impregnated, sound-deadening full-face honeycomb core.

2.03 CONSTRUCTION

- A. Doors and panels shall be 1" thick. Edges shall be sealed with a 22-gauge steel interlocking molding. Molding corners shall be welded to each other and to face sheets, and ground smooth to form a rigid frame around the component.
- B. Pilasters shall be 1-1/4", constructed of two sheets of 18-gauge galvanized steel, formed and bonded under pressure with a non-toxic adhesive to a full resin-impregnated, sound-deadening full-face honeycomb core. Vertical edges shall be sealed with 20-gauge steel interlocking molding. The bottom of each pilaster shall be sealed with a 22-gauge steel interlocking molding. An 11-gauge slotted stirrup bracket shall be integrally welded on to top of each pilaster. Two 3/8" diameter by 6" long cadmium-plated studs anchor the mounting bracket to overhead structural steel members. A shoe shall conceal each ceiling mounting, having an internal cross section conforming to the pilaster, and being formed of type 304 stainless steel #4 finish.
- C. All units shall be cleaned prior to application of baked GLO-GARD hybrid powder coating of at least 1.3 mil thickness.

2.04 HARDWARE (NOTE: Refer to the ORDER INFORMATION CONTRACT for specific hardware to be supplied on your order.)

- A. All exposed door hardware shall be of chromium-plated diecast Zamac and shall be as noted:
 - 1. Upper door hinge is recessed and interlocked in door and includes a nylon pin within the plane of the door. Lower door hinge is recessed in door and includes mating box and pintle nylon cams, which provide the bearing surface. The cams are adjusted to allow the door to rest at any position within a 270-degree range.
 - 2. Door hardware shall include a coat hook, bumper, stop, keeper and a concealed latch with emergency access.
- B. Wall brackets shall be secured to walls with anchoring and/or expansion shields.
- C. Pilaster shoes shall be of type 304 stainless steel #4 finish.
- D. Fasteners shall be of chrome-plated steel; door hinges and latches will be mounted with tamper resistant barrel nuts and machine screws; hooks and handles will be mounted with tamper resistant full-thread screws.

PART-3 EXECUTION

3.01 PREPARATION

- A. Examine areas to receive toilet compartments for correct height and spacing of anchorage/blocking and plumbing fixtures that may affect installation of compartments. Report any discrepancies to the architect.
- B. Take complete and accurate measurements of toilet compartment locations.
- C. Start of work constitutes acceptance of job.

3.02 INSTALLATION

- A. Install compartments in a rigid, straight, plumb and level manner as shown on the shop drawings and manufacturer's installation instructions.
- B. All doors and panels to be mounted at 12" above the finished floor unless otherwise specified.
- C. Clearance at vertical edges of door shall be uniform top to bottom.
- D. No evidence of cutting, drilling and/or patching shall be visible on the finished work.
- E. Finished surfaces shall be cleaned after installation and be left free of all imperfections.

3.03 WARRANTY

- A. Global Partitions guarantees its powder coated steel units, properly maintained, against corrosion or discoloration for 3 years from the date of receipt by the customer. If materials are found defective during that period for the reasons listed above, the material will be replaced free of charge. No credits or allowances will be issued for any labor or expenses relating to the replacement of components covered under the warranty plan. All such expenses are to be borne by the buyer.

2.05

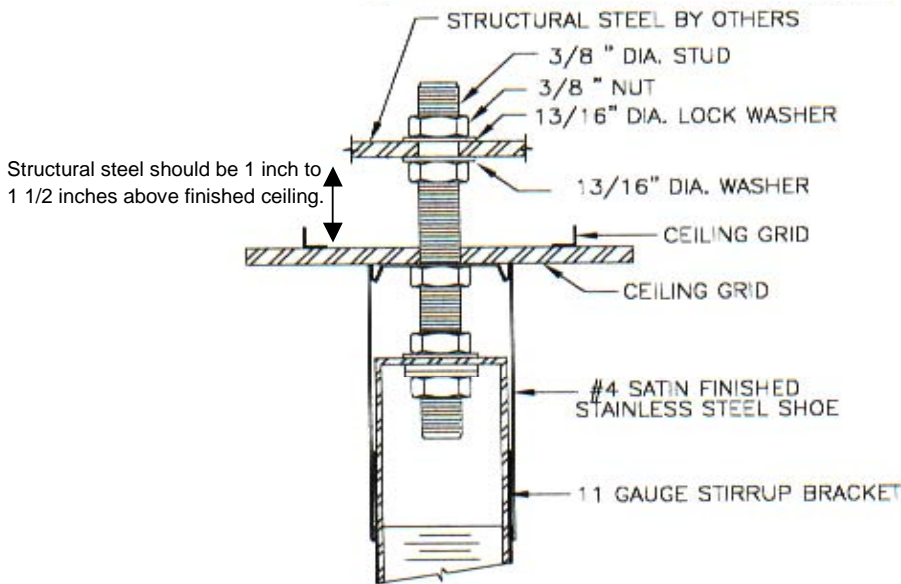
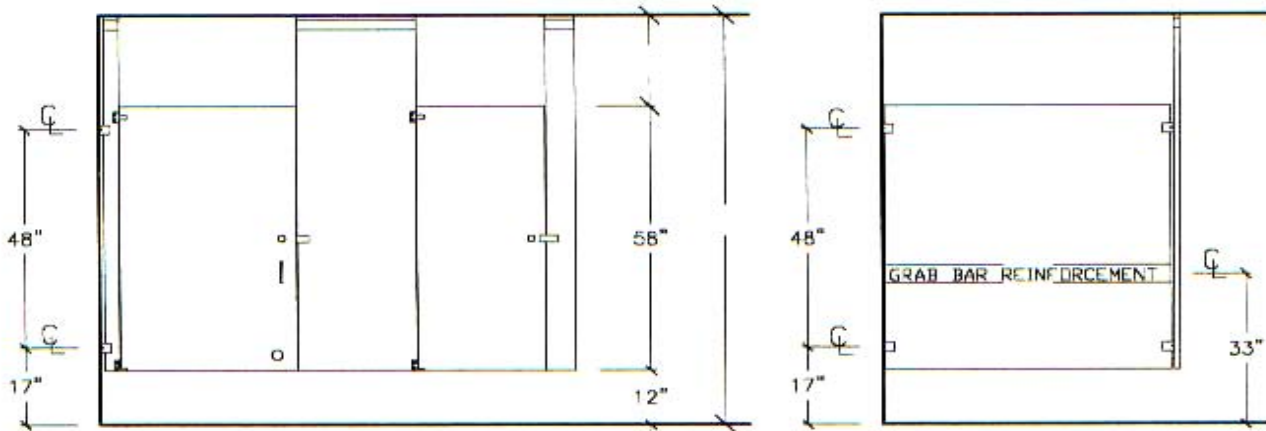

CEILING BOLT DETAIL
METAL PILASTERS

CROSS SECTION

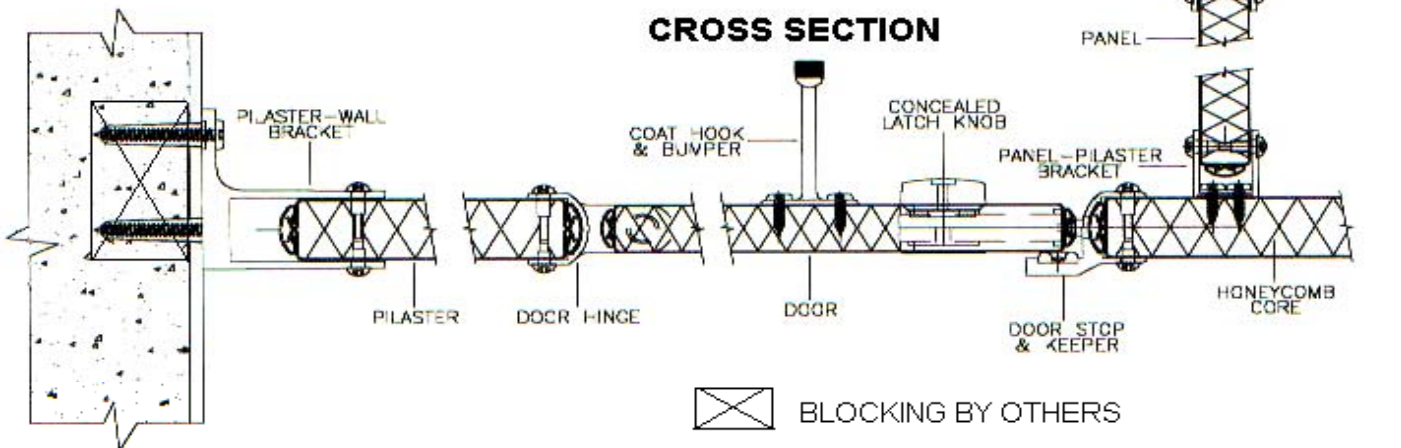

PART-1 GENERAL

**MAXIMUM CEILING HEIGHT 9'0"
MINIMUM CEILING HEIGHT 7'6"**

1.01 DESCRIPTION

- A. Steel compartment work includes the following:
 - 1. Floor and ceiling anchored partitions.
- B. Furnish all labor and materials necessary for the completion of work in this section as shown on the contract drawings and specified herein.
- C. Work in this section shall include but is not limited to:
 - 1. Toilet compartments
 - 2. Hardware for toilet compartments
 - 3. Shop drawings and working drawings
 - 4. Manufacturer's guarantee
- D. Related work specified elsewhere shall include accessories and anchorage/blocking for attachment of compartments.

1.02 PRODUCTS

- A. Submittal of shop drawings and details, for architect's approval.
- B. Colors shall be selected from the manufacturer's standard range of colors.
- C. Color and hardware samples shall be submitted for approval to the architect upon request.

PART-2 PRODUCTS

2.01 MANUFACTURER

- A. Toilet compartments to be supplied by Global Partitions, Eastanollee, GA 30538.

2.02 MATERIALS

- A. Doors and panels shall be 1" thick, constructed of two sheets of 22-gauge galvanized, stretcher leveled quality steel formed and bonded under pressure with a non-toxic adhesive to a resin-impregnated, sound deadening, honeycomb core. Pilasters shall be 1-1/4", constructed of two sheets of 22-gauge galvanized stretcher leveled quality steel, formed and bonded under pressure with a non-toxic adhesive to a resin-impregnated, sound-deadening full-face honeycomb core.

2.03 CONSTRUCTION

- A. Doors and panels shall be 1" thick. The edges shall be sealed with a 22-gauge, steel interlocking molding. Molding corners shall be welded to each other and to face sheets, and ground smooth to form a rigid frame around the component.
- B. Pilasters shall be 1-1/4" thick. Vertical edges shall be sealed with a 22-gauge steel interlocking molding. Stirrup brackets with a jack bolt, for leveling during installation and permanent height adjustment, shall be welded within both top and bottom of each pilaster. "L" brackets shall be coupled to the stirrup brackets at both the floor and ceiling for full range adjustment. A shoe shall conceal each mounting, having an internal cross section conforming to the pilaster, and being formed of type 304 stainless steel #4 finish.
- C. All units shall be cleaned prior to application of a baked GLO-GARD hybrid powder coating of at least 1.3 mil thickness.

2.04 HARDWARE (NOTE: Refer to the ORDER INFORMATION CONTRACT for specific hardware to be supplied on your order.)

- A. All exposed door hardware shall be of chromium-plated diecast Zamac and shall be as noted:
 - 1. Upper door hinge is recessed and interlocked in door and includes a nylon pin within the plane of the door. Lower door hinge is recessed in door and includes mating box and pintle nylon cams, which provide the bearing surface. The cams are adjusted to allow the door to rest at any position within a 270-degree range.
 - 2. Door hardware shall include a coat hook, bumper, stop, keeper and a concealed latch with emergency access.
- B. Wall brackets shall be secured to walls with anchoring and/or expansion shields.
- C. Pilaster shoes shall be of type 304 stainless steel #4 finish.
- D. Fasteners shall be of chrome-plated steel; door hinges and latches will be mounted with tamper resistant barrel nuts and machine screws; hooks and handles will be mounted with tamper resistant full-thread screws.

PART-3 EXECUTION

3.01 PREPARATION

- A. Examine areas to receive toilet compartments for correct height and spacing of anchorage/blocking and plumbing fixtures that may affect installation of compartments. Report any discrepancies to the architect.
- B. Take complete and accurate measurements of toilet compartment locations.
- C. Start of work constitutes acceptance of job.

3.02 INSTALLATION

- A. Install compartments in a rigid, straight, plumb and level manner with steel as shown on the shop drawings and manufacturer's installation instructions.
- B. All doors and panels to be mounted at 12" above the finished floor unless otherwise specified.
- C. Clearance at vertical edges of door shall be uniform top to bottom.
- D. No evidence of cutting, drilling and/or patching shall be visible on the finished work.
- E. Finished surfaces shall be cleaned after installation and be left free of all imperfections.

3.03 WARRANTY

- A. Global Partitions guarantees its powder coated steel units, properly maintained, against corrosion or discoloration for 3 years from the date of receipt by the customer. If materials are found defective during that period for the reasons listed above, the material will be replaced free of charge. No credits or allowances will be issued for any labor or expenses relating to the replacement of components covered under the warranty plan. All such expenses are to be borne by the buyer.

2.07

Structural steel should be 1 inch to 1 1/2 inches above finished ceiling

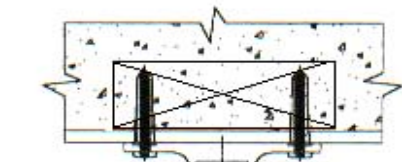
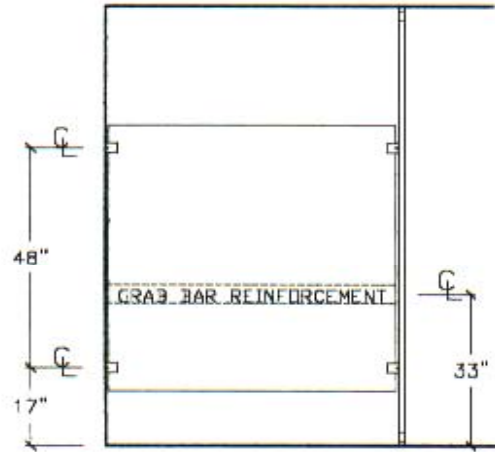
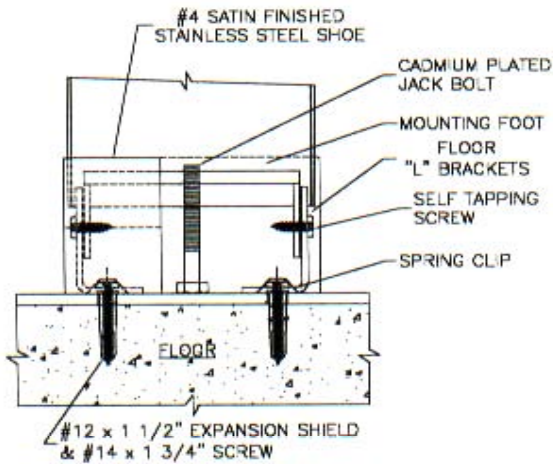
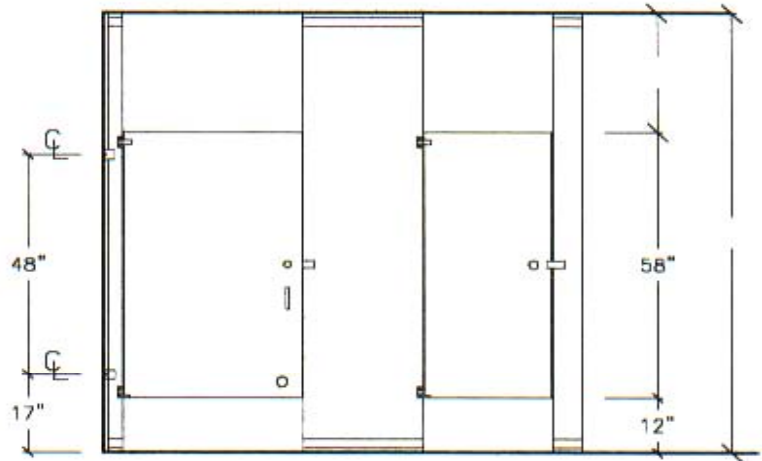
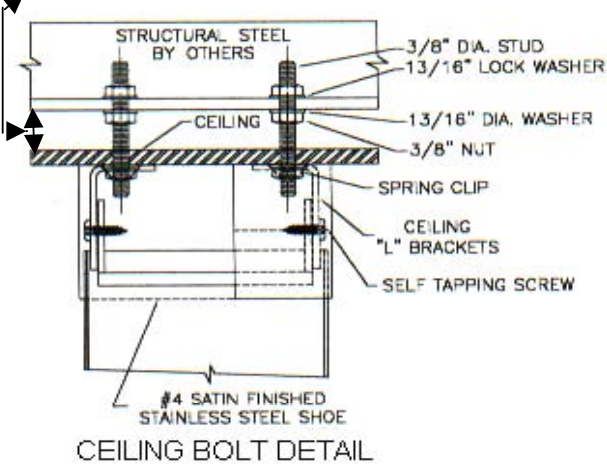

CROSS SECTION

